

Back Water Valve

- 100% tested for safety and comply with the guidelines set out in BS EN 13564
- Robust design and maintenance-free operation
- Stainless steel anti-flooding flaps
- Special design of the body minimises the risk of solid waste accumulating and blocking inside the valve
- Also suitable as a rodent deterrent

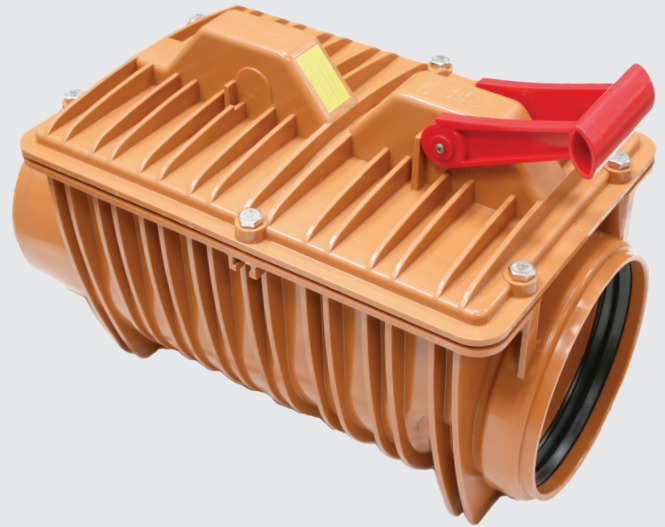

Backwater Valve are installed in-line along the drainage system to allow sewer or surface water materials to freely flow in the direction of the systems mains but block backflow of those materials in the opposite direction in instances, such as, flooding.

Protect buildings against backwater flooding due to rainwater travelling back up the sewerage system.

Automatically operated, providing free-flow wastewater drainage according to the slope of the rainwater drain.

These backwater valves are available in a wide range of sizes and are easy to install in waste water networks and systems with pipes of Ø110 to Ø200.

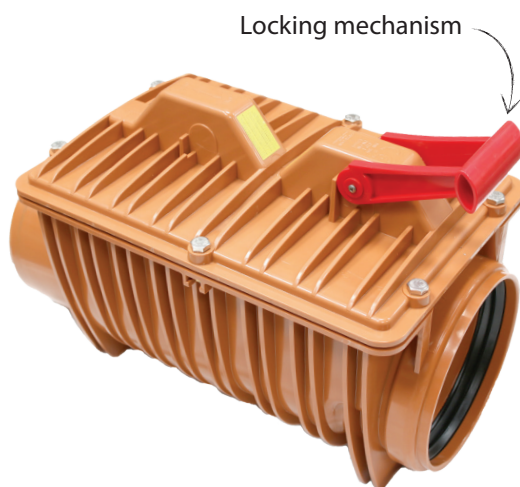

Product Code	Description	Ø (mm)	A Height (mm)	B Width (mm)	C Length (mm)	Weight (Kg)
BWV110/1	110mm Back Water Valve	110	200	190	310	1.42
BWV160/1	160mm Back Water Valve	160	260	235	340	2.3
BWV200/1	200mm Back Water Valve	200	353	304	560	6.6

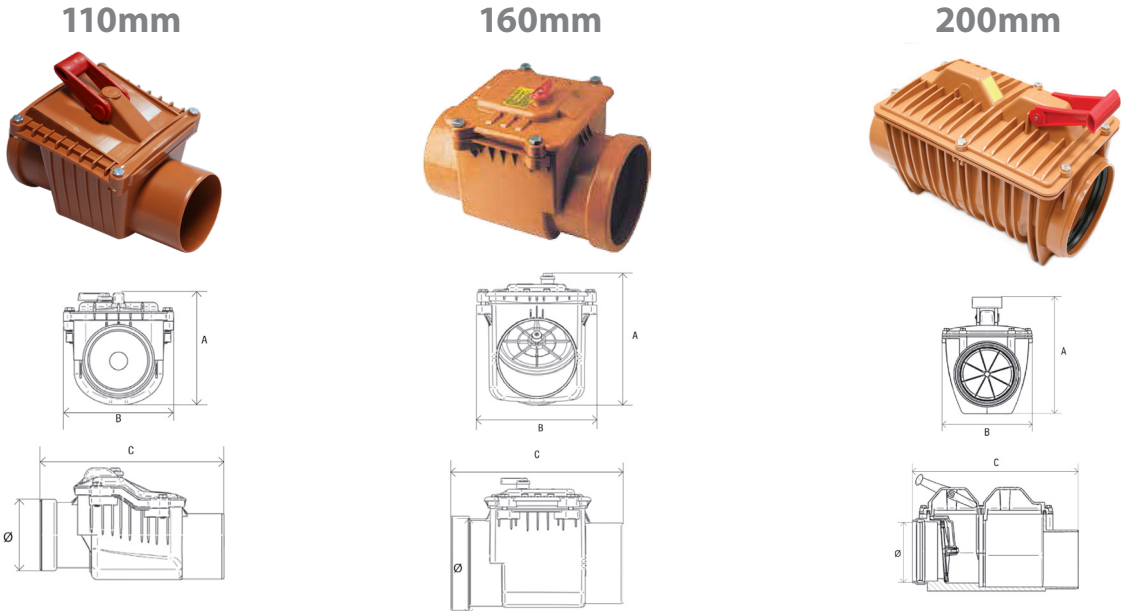

Back Water Valves, Double Flap - Suitable for foul sewerage systems

Product Code	Description	Ø (mm)	A Height (mm)	B Width (mm)	C Length (mm)	Weight (Kg)
BWV110/2	110mm Back Water Valve	110	195	205	395	1.86
BWV160/2	160mm Back Water Valve	160	273	304	577	5.05
BWV200/2	200mm Back Water Valve	200	353	304	560	7.5

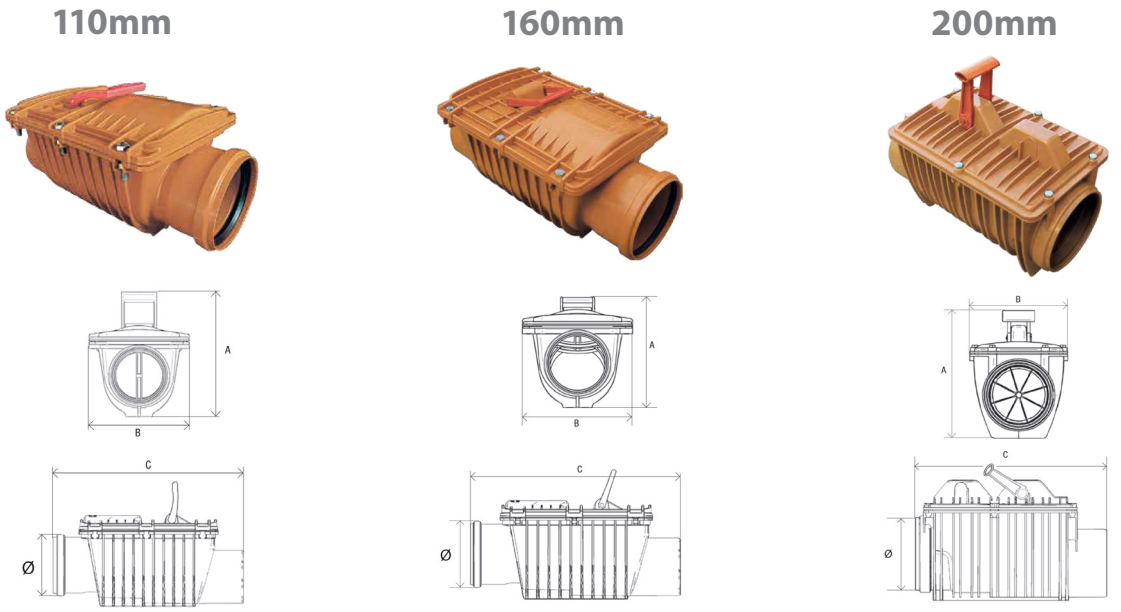

General Information

Quality, Standards and Approvals

Fernco has been certified by the British Standards Institution (BSI) as a company of assessed capability, with a quality management system which meets the requirements of BS EN ISO 9001:2015

Fernco, part of the Fernco Group, are the leaders in wastewater connection innovation; utilising the most advanced methods and techniques for precision-manufactured products, all of which comply with or exceed relevant British and European standards to ensure reliability and sustainability.

Environment

Fernco operate Environmental Management Systems which are certified to ISO 14001: 2015.

Supply

Fernco are proud members of the Builders Merchants Federation (BMF). All Fernco products are supplied through a national and global network of distribution and merchant partners. For stockist details, contact Fernco.

Technical Support

Fernco have a team of product experts on hand to support all customers with technical support and advise.

Contact Fernco Technical Department:

Tel: +44 (0) 1226 344100

Email: technical@fernco.co.uk

Enquiries

UK Sales:

Tel: +44 (0) 1226 340 888

Email: sales@fernco.co.uk

International Sales:

Tel: +44 (0) 1226 344 105

Email: export.dept@fernco.co.uk